

## Production range pumps:

### Pumps with magnet drive

- ▶ Centrifugal pumps according to DIN EN 22858
- ▶ Centrifugal pumps according to ANSI B73.3
- ▶ Centrifugal pumps for refinery and petrochemical applications according to API 685
- ▶ Centrifugal pumps for high pressure applications
- ▶ Centrifugal pumps for high temperature applications
- ▶ Centrifugal pumps for liquid containing solids
- ▶ Centrifugal pumps, self-priming
- ▶ Multistage pumps, tension-rod or barrel-type construction
- ▶ Side channel pumps, self-priming
- ▶ Screw pumps
- ▶ Submerged centrifugal pumps
- ▶ Double suction centrifugal pumps

### Pumps with shaft sealing

- ▶ Centrifugal pumps according to DIN EN 22858
- ▶ Multistage pumps, tension-rod or barrel-type construction
- ▶ Horizontal and vertical propeller pumps
- ▶ Bottom-flange propeller pumps
- ▶ Submerged centrifugal pumps
- ▶ Double-suction chemical pumps

### Production range agitators:

- ▶ Agitator drives with magnet drive

### Production range valves:

- ▶ Valves, T-pattern
- ▶ Valves, Y-pattern
- ▶ Gate valves, isomorphous construction series
- ▶ Gate valves, wedge or wedge plates
- ▶ Relief valves
- ▶ Check valves
- ▶ Sight glasses
- ▶ Strainers
- ▶ Filters
- ▶ Bottom valves



KU\_GV\_E\_04/09\_0001



## MULTISTAGE CENTRIFUGAL PUMP TYPE SLM GV

SEALLESS WITH MAGNET DRIVE

### Klaus Union GmbH & Co. KG

Blumenfeldstr. 18  
44795 Bochum  
Germany

Phone +49 234 45 95 - 0  
Fax +49 234 45 95 - 7000

E-Mail [info@klaus-union.de](mailto:info@klaus-union.de)  
Internet [www.klaus-union.de](http://www.klaus-union.de)

# Safety and environmental protection

## Sealless multistage centrifugal construction series SLM GV

As a member of Klaus Union's successful modular pump concept, the SLM GV further extends our sealless application coverage. The SLM GV pump is primarily used for applications requiring high delivery heads.

Requirements have increased, become more complex, and more specific in recent years, particularly in the chemical and petrochemical industry, where pumps handle aggressive, toxic, and explosive liquids under highest safety requirements. Klaus Union's new SLM GV pump series addresses today's industry requirements – and offers new efficient and demand-driven solutions.

Klaus Union satisfies these requirements with over fifty years of experience in development, construction, manufacturing, and in the application of magnet drive pumps.

SLM GV – “V” stands for “variable” through modular design. Features and benefits of the modular “V-Concept” are:

- ▶ Few individual components – multi-functional, individual application
- ▶ Greater safety over the entire construction range
- ▶ Suitable for serial fabrication at competitive prices
- ▶ Standard modules offer many design variations
- ▶ Energy efficient systems
- ▶ Maximum flexibility and interchangeability
- ▶ Off-the-shelf availability of parts, components and accessories

The construction series SLM GV covers the complete performance range of multistage centrifugal pumps. Pumps for high system pressure applications are also available upon request.

## Quality assurance

A major component of our Company ethos is to ensure the highest quality of our products. Existing quality assurance procedures with our suppliers are constantly monitored from order placement, goods inward through to final assembly. This quality assurance system, developed on modern principles, complies with the requirements of international regulations. Klaus Union is a DIN EN ISO 9001:2000 certified Company and is certified accordingly.

## Performance range

Flow rate: Q = up to 350 m<sup>3</sup>/h  
 Delivery head: H = up to 700 m L. C.  
 Higher flow rates and delivery heads upon request

## Pressure ratings/temperature ranges

Standard construction: PN 40 / PN 63 at 120 °C  
 Temperature range: -120 °C up to +450 °C  
 Higher pressure ratings upon request



SLM GV0T Barrel construction type design



SLM GVS tension rod construction design



# Constructional details SLM GVOT Barrel-type construction

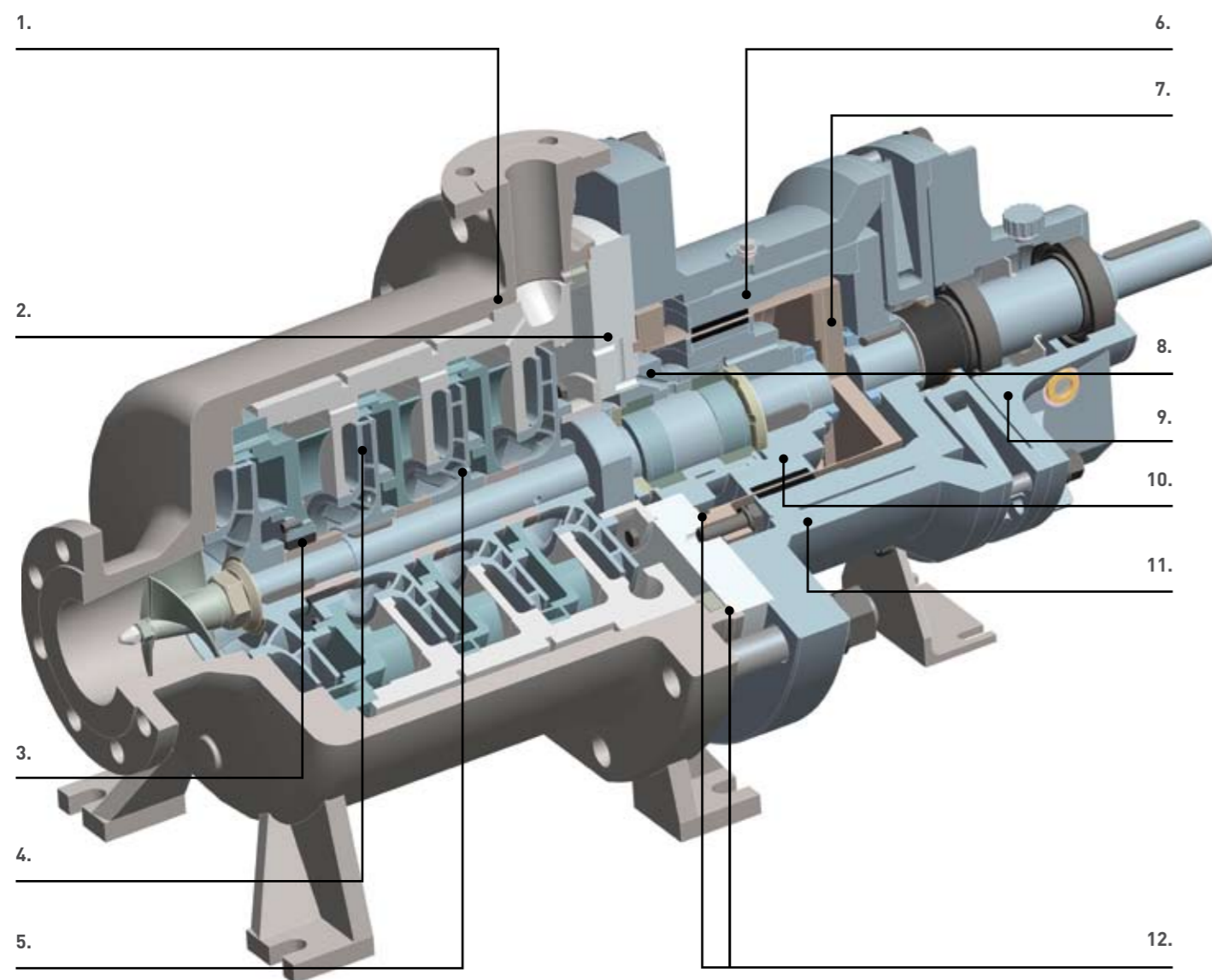

## 1. Barrel-type pump casing

PN 40 / PN 63 at 120 °C;  
Suction nozzle with horizontal inlet  
**Optionally** with heating jacket

## 2. Flushing system

Pressurised to safely handle liquids close to boiling

## 3. Radial journal bearing

Radial journal bearing behind the suction impeller

## 4. Impellers

Arranged in series;  
First stage with suction impeller  
**Optionally** with suction inducer to reduce required NSPH

## 5. Balancing holes

Optimized thrust loads over the entire operating range via hydraulic measures

## 6. Outer magnet carrier

Two piece with rub ring on the intermediate lantern

## 7. Isolation shell

Self-venting and fully drainable;  
Vortex breaker

## 8. Journal bearings

Double bearing made of SSiC;  
Counter centred combination for universal utilisation over a wide temperature range

## 9. Bearing support

Oil-lubricated anti-friction bearings: SLM GVOT design  
**Optionally** with grease-lubricated anti-friction bearings: SLM GVST design

## 10. Inner magnet carrier

With rub ring on the journal bearing bush

## 11. Intermediate lantern

With outer magnet carrier rub ring and assembly/disassembly guidance

## 12. Static gasket

Merely two static gaskets on isolation shell and casing



# Performance curves SLM GV

Performance curve 50 Hz

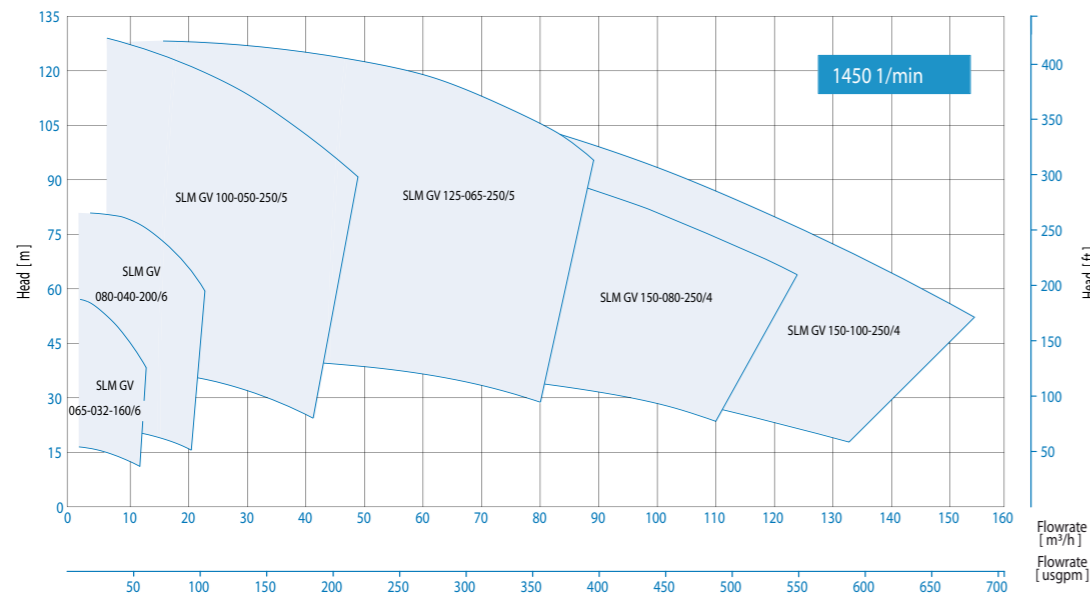

Performance curve 60 Hz

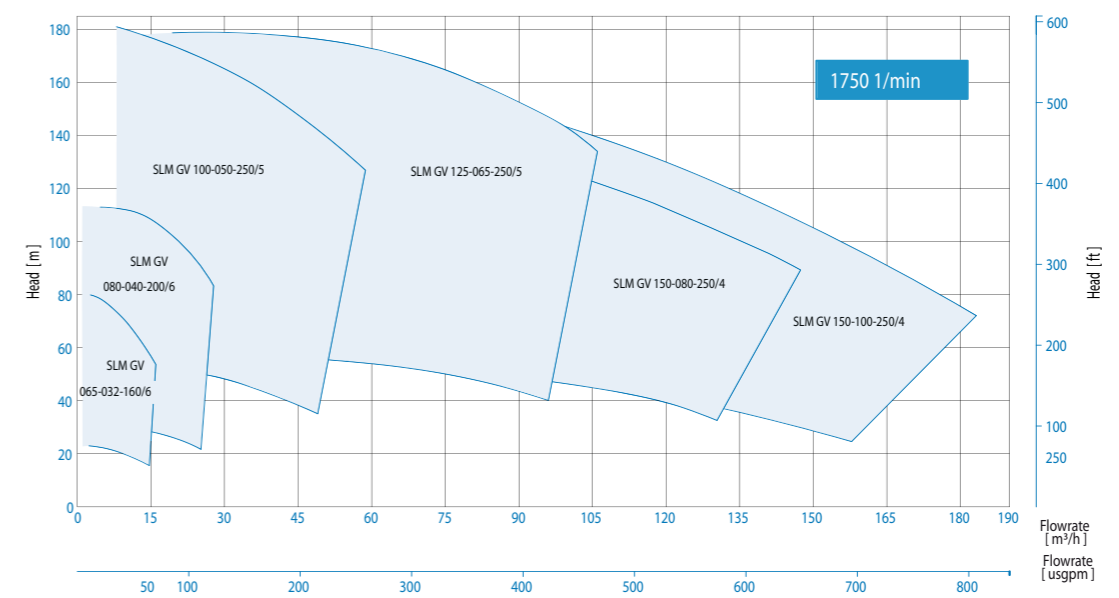

Performance curve 50 Hz

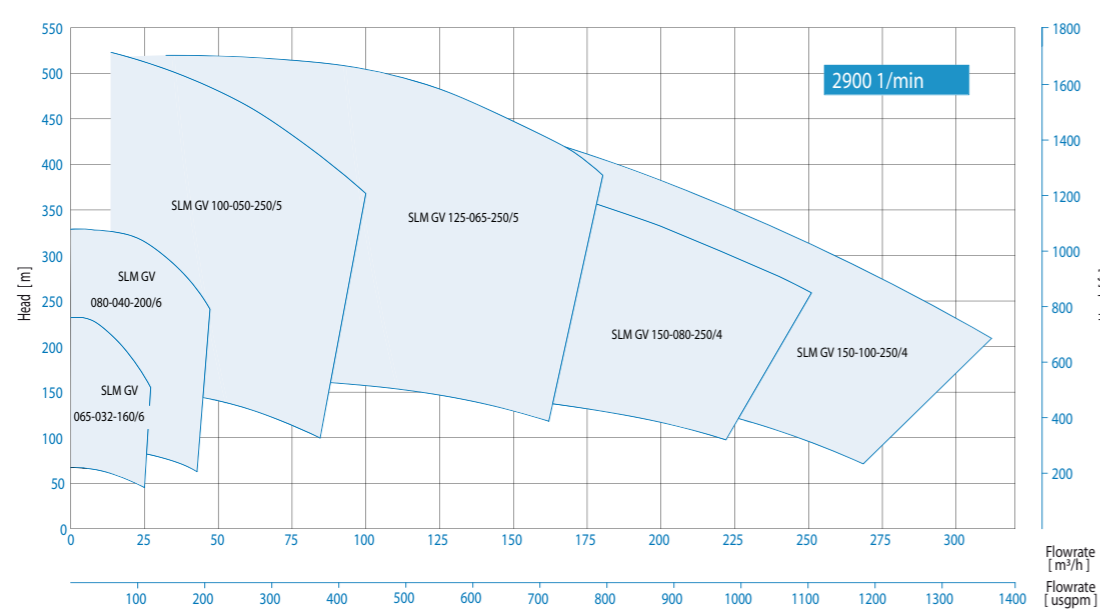

Performance curve 60 Hz

